

DOOSAN

Construction Equipment

DX1000LC-7

Engine Power

T3 ISO 14396, Gross 470 kW (639.2 PS)@ 2,100 rpm
SAE J1349, net 470 kW (639.2 PS)@ 2,100 rpm

T4F,S5 ISO 14396, Gross 469 kW (629 PS)@ 2,000 rpm
SAE J1349, net 469 kW (629 PS)@ 2,000 rpm

Operating Weight

97,000 ~ 99,500 kg

Bucket Capacity (SAE/PCSA)

5.4 ~ 6.8 m³



Powered by Innovation

DO BIG JOBS BETTER WITH STRONGER

DX 1000LC



The DX1000LC-7 is designed for maximum productivity with outstanding performance, durability and surprisingly high fuel efficiency. Serving as your reliable partner, it will enable you to work in harsh mining environments where avoiding downtime is critical.

OVERVIEW OF DX1000LC-7

HIGH PRODUCTIVITY AND LOW COST OF OWNERSHIP

Delivers higher productivity and reduced fuel consumption for efficient and comfortable work environment.

ENGINE

Exceptionally powerful – with high torque at low revs – the Perkins 2806D (T3), 2806J (T4F/StageV) engine combines reliability and low environmental impact. This T4F, T3 and S5 compliant 6 cylinder engine delivers 470 kW @ 2,100rpm (T3), 469 kW @ 2,000rpm (T4F/StageV).

RELIABILITY

Designed for the toughest applications and the most abrasive environment.

SAFETY

Your safety is our priority: Optional Around View Monitoring (AVM) system, large side mirrors, Powerful LED work lights, anti-slip steps and platforms, guard rails on upper structure.

MASS EXCAVATION

2 Heavy duty(HD) front combinations available to match various conditions. Mass excavation front with large bucket size or heavy-duty fronts when long reach is needed.

SWING BEARINGS

Unique design of crossed bearing providing longer lifetime with lower stress distribution.

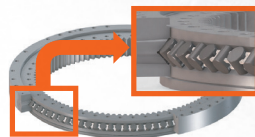

EASY MAINTENANCE

Automatic greasing system as an option, all filters easily accessible, compressor with air gun as option, everything designed for easy maintenance.

COMFORT

One of the most spacious cabs in the market, with low noise & vibration levels and excellent all-round visibility. Fully adjustable heated air-suspension seat, air conditioning with climate control as standard.

UNDERCARRIAGE DURABILITY

Heavy-duty undercarriage, with large rollers and sprocket, enhanced frame for the toughest applications.

EXCELLENT FUEL EFFICIENCY

The Smart Power Control (SPC) system increases fuel efficiency by adjusting the power to meet the application's needs.

ADVANCED FILTRATION

High efficiency filters & cleaners remove water, dust & particles to protect your investment optimally.

OPERATION AT EASE

All important information is at your fingertips with the new easy-to-use 8" touch screen. Exclusive jog shuttle switch, 4 work & 4 power modes, proportional control.



PERFORMANCE AND PRODUCTIVITY

New and Intelligent Hydraulic System Deliver The Best-In-Class Productivity.

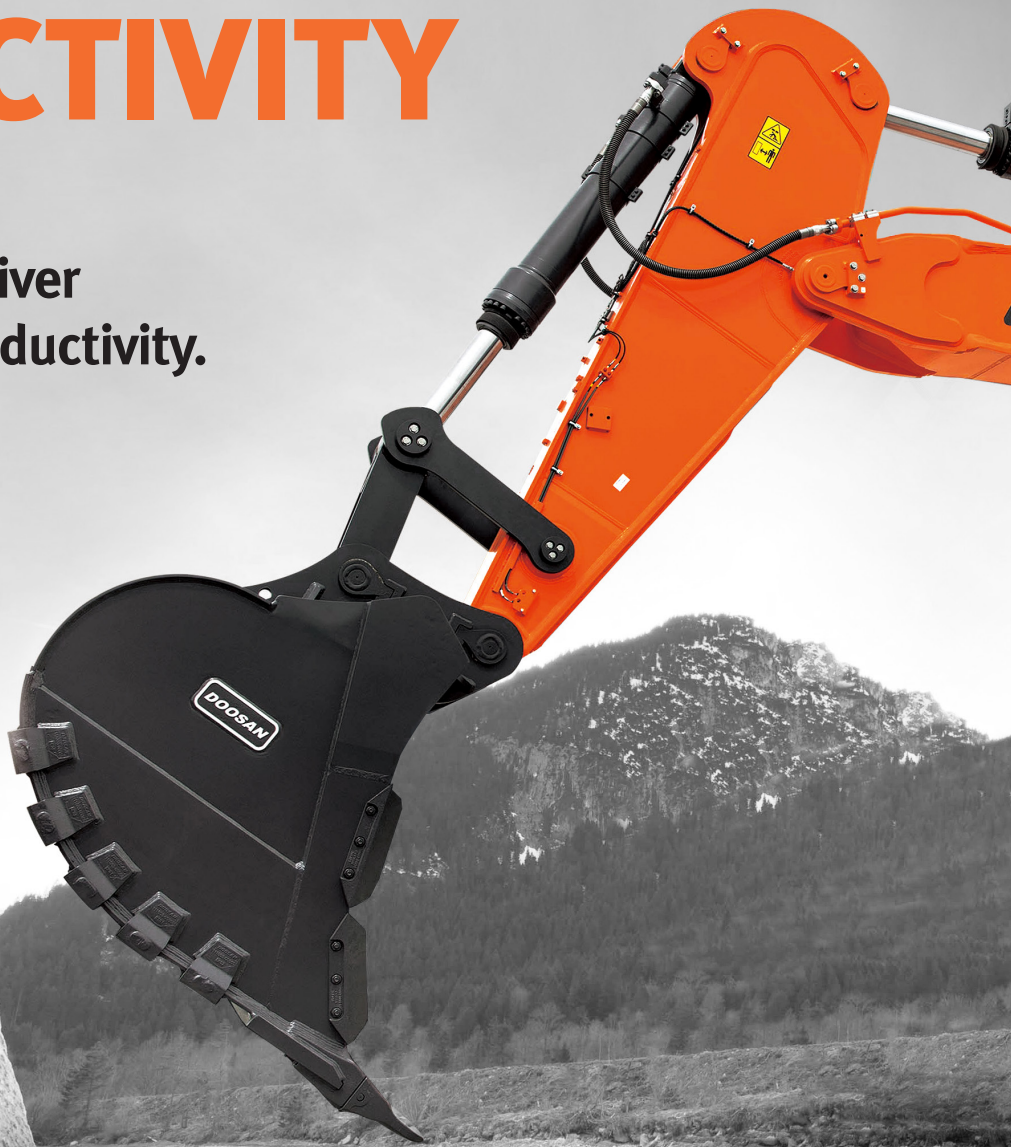

ENGINE WITH ENHANCED POWER AND RELIABILITY

Manufactured in a world-class facility for reliability and durability, the DX1000LC-7 engine ensures many years of productive life to keep your machine running efficiently and effectively even under the toughest jobsite conditions. Along with this, it allows you to maintain your machine at a low cost throughout its lifetime with features that minimize service costs combined with low fluid consumption.

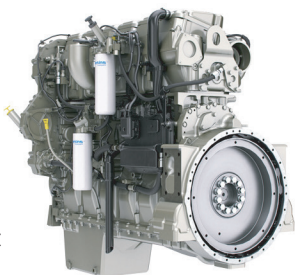

* Actual product may differ from the image shown above.

THE MOST ADVANCED HYDRAULIC SYSTEM (D-ECOPOWER+)

This new electronic main pump accurately calculates the amount of pump flow required for each actuator, thereby maximizing productivity (faster operation) and avoiding unnecessary fuel loss.

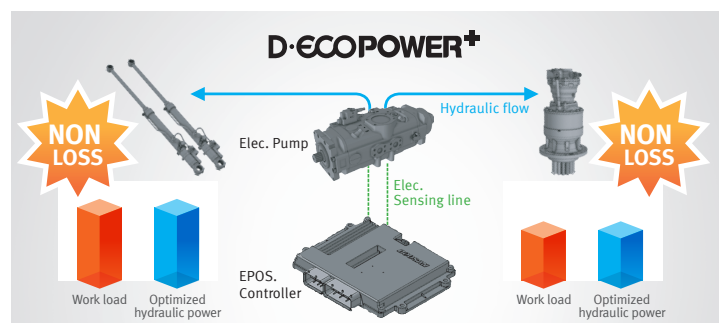



18%
HIGHER
PRODUCTIVITY

Internal test result vs. DX800LC
(Maximum size bucket)

EPOS CONTROLLER

MCV

ADVANCED ELECTRONIC MAIN PUMP

MCV II

SELECTABLE OPERATING MODES OPTIMIZED FOR VARIOUS WORK ENVIRONMENTS

Boom/Swing Priority Control

Allows you to control operating modes with just one button and provides optimized level, resulting in a more comfortable and productive operation.

BOOM PRIORITY MODE

Hydraulic power

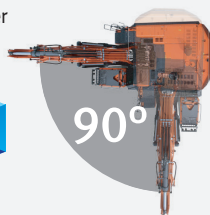

SWING PRIORITY MODE

Hydraulic power

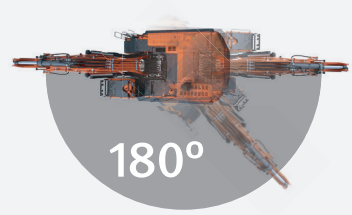
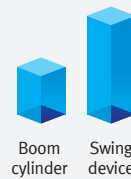

EFFICIENT FUEL MANAGEMENT

- Choice of 4 power modes and 4 working modes offers optimum performance in all conditions.
- Smart Power Control (SPC) system: provides optimal engine speed and pump torque according to work conditions. The system automatically adjusts engine power and hydraulic output to improve fuel efficiency and reduce emissions.
- Engine auto-shut-off: shuts down the engine after the machine has been idling for a specified time. The operator can set the delay before shut-off via the touchscreen.

Smart pump control SPC Smart engine control

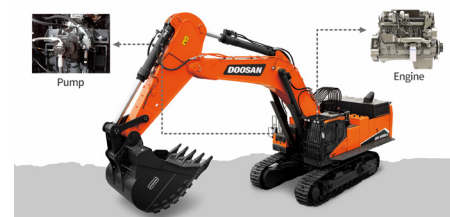

INCOMPARABLE DURABILITY

Built With Quality-Proven Main Components And Durable Design For Minimized Downtime

QUALITY-PROVEN MAIN COMPONENTS

Manufactured with the finest quality main components customized precisely for large equipment, this new machine offers the Best-in-Class power and durability.



A. SWING MOTOR

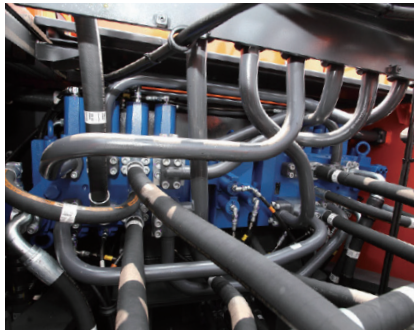

B. MCV

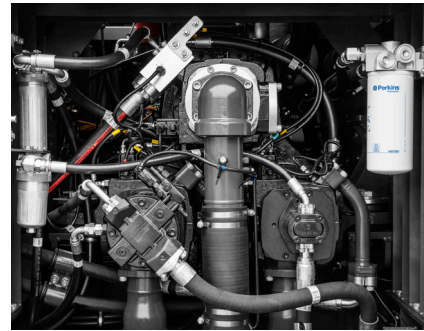

C. MAIN PUMP

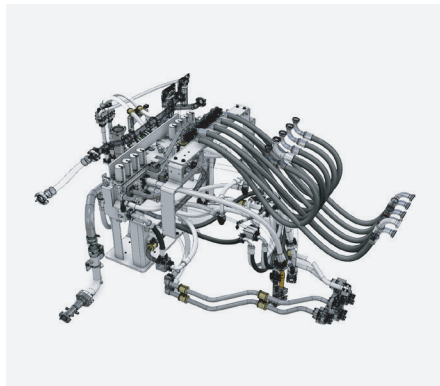

PROTECTED HYDRAULIC SYSTEM

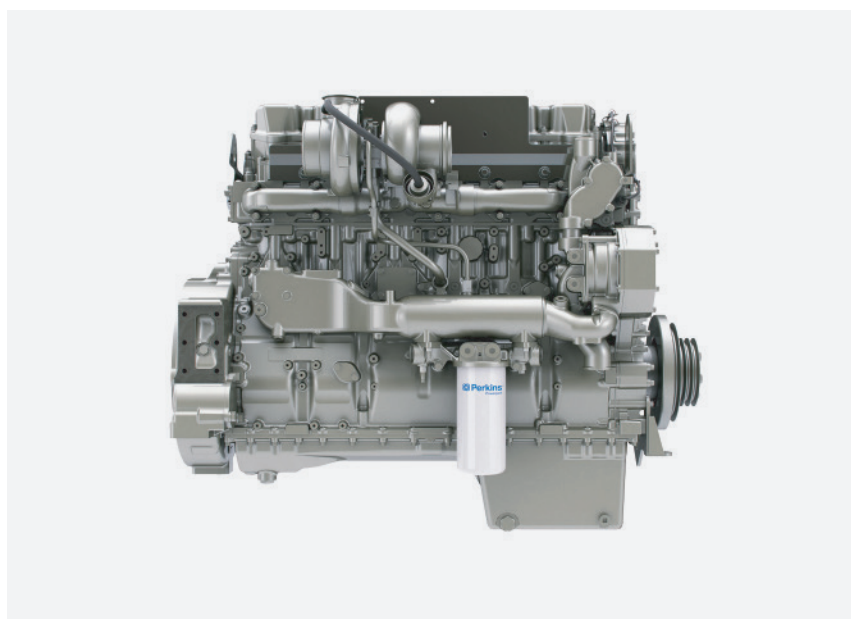

D. ENGINE

* Actual product may differ from the image shown above.

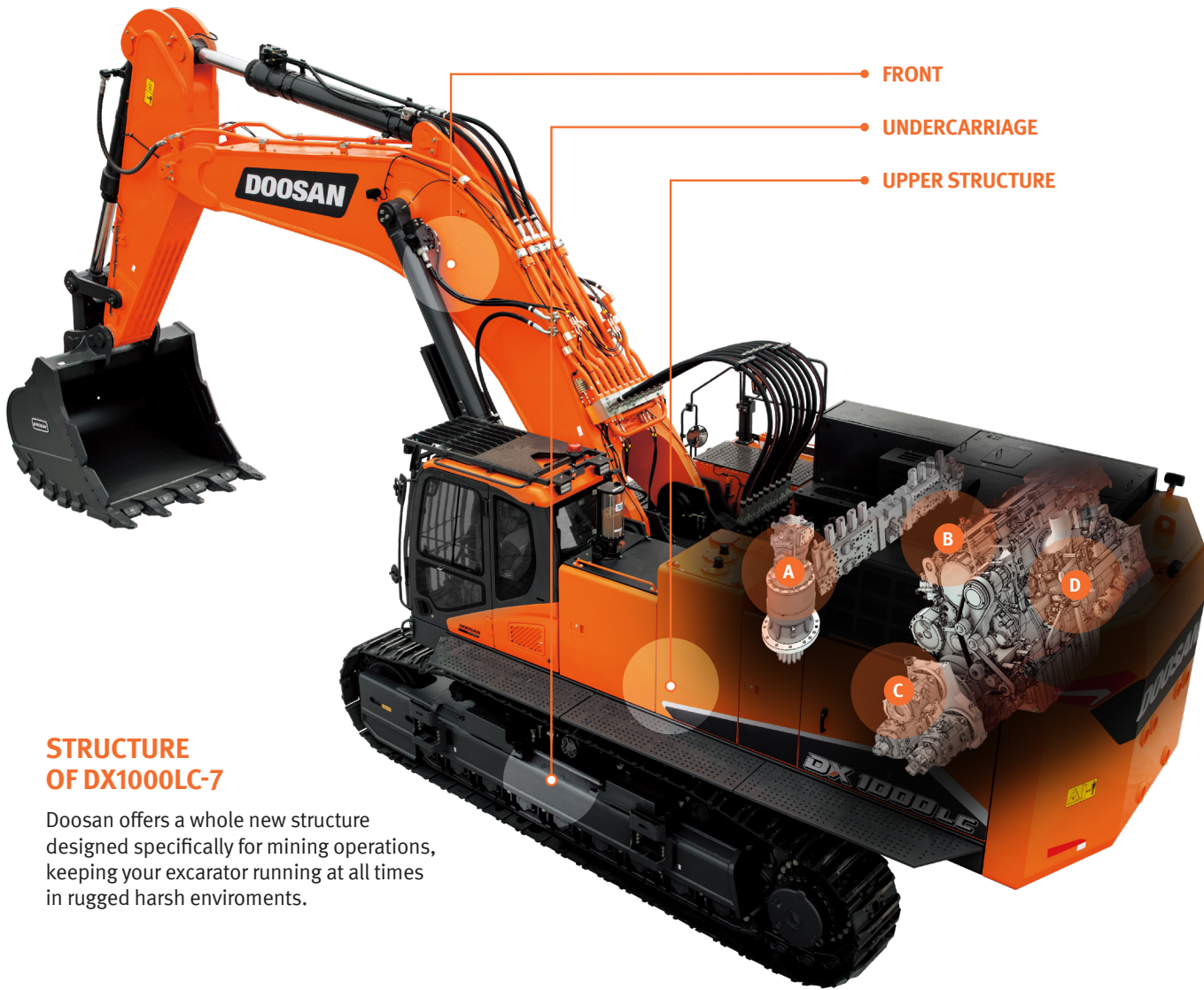

STRUCTURE OF DX1000LC-7

Doosan offers a whole new structure designed specifically for mining operations, keeping your excavator running at all times in rugged harsh environments.

HEAVY DUTY FRONT

Performance of the boom and arm of the DX1000LC-7 has considerably enhanced the overall durability of the machine.

BOOM

1. Boom foot design to increase the pin strength and decrease one-side wear of pin.
2. Flat steel plate for dispersing machine stress.
3. Welding design to increase welding part lifetime.
4. Inner reinforce plate changed for dispersing stress.

ARM

5. Bottom steel plate of arm to increase strength of arm structure.
6. Arm center boss to lower stress.
7. Arm welding design to decrease stress.
8. Diameter of pin (130 ▶ 140) to increase pin strength.

UPPER STRUCTURE



9. HEAVY DUTY UNDER COVER

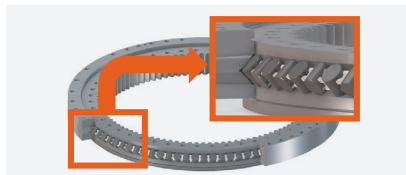

10. CROSSED ROLLER SWING BEARINGS
Unique design of crossed bearing providing longer lifetime with lower stress distribution.

UNDERCARRIAGE



11. FRAME

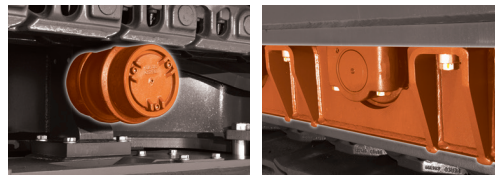

12. UNDERCARRIAGE
Our heavy duty undercarriage further increases durability of your machine.

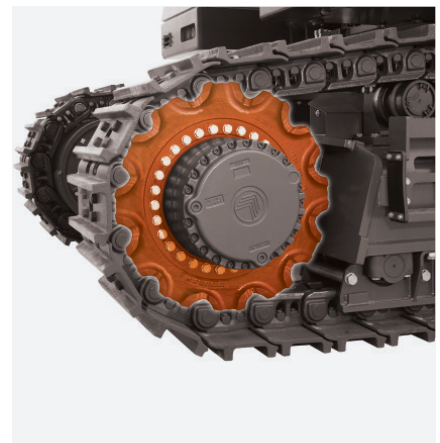

13. HEAVY-DUTY SPROCKET
Our heavy duty sprocket further increases durability of your machine.

COMFORT AND SAFETY

Safety Comes In First With Enhanced Safety Features



* Actual product may differ from the image shown above.

LED WORKING LAMP

More productive at night with highly improved sight.



AROUND VIEW MONITOR (AVM) SYSTEM

Provides 360-degree view in your cabin through AVM system.



8" TOUCH SCREEN

An easy to read and use 8" touch screen integrated all function in one place

DOOSAN SMART KEY

We bring automotive standard and comfort to construction machinery

- Search function
- Coming/leaving home light function
- Remote door opening
- Keyless engine start



ERGONOMICALLY DESIGNED PEDAL

Ergonomically designed travel pedals placed in the middle. Pedal angle adjusted to relieve the pressure on ankle and joints, reducing fatigue and to lessen the load of operator.



EASY MAINTENANCE



AIR COMPRESSOR

Air gun in your cabin helps you to keep clean and comfortable ambience.

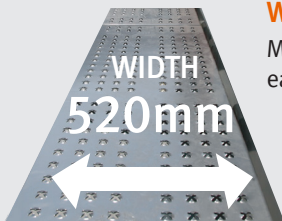

WIDE CATWALK

Maintenance is made easier with 520mm catwalk.

* Actual product may differ from the image shown above.

We Offer Easy, Breezy Maintenance System That Can Also Prevent Downtime Of Your Machine.

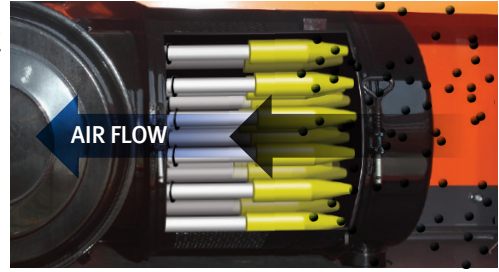
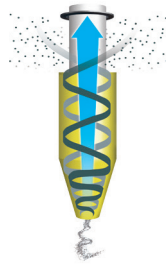

HEAVY DUTY AIR CLEANER

Protects from dust and contaminated particles with a two-stage air cleaner, enabling easy maintenance and downtime avoidance.

REVERSIBLE FAN

- Rotating cooling fan in reverse direction is possible.
- Able to blow away dust on radiator and oil cooler easily to save time & effort.

AUTO GREASE SYSTEM (AGS)

This new auto grease filling device helps reduce maintenance time significantly and avoid unexpected downtime.

ELECTRIC FUEL TRANSFER PUMP (ETP)

Use this switch to easily refill fuel for your machine after its inspection or repair.

CENTRALIZED FUEL FILTRATION SYSTEM

Water separator, pre-fuel filter and main filter are grouped together to increase engine life and prevent machine failures, making machine inspection or maintenance much easier with one simple access.



TECHNICAL SPECIFICATION

ENGINE

Model

Perkins 2806D (T3)
Perkins 2806J (T4F,S5)

Type

Turbocharged after WATER-COOLED
MEUI (Mechanically Actuated Electronically Controlled Unit Injector)

Number of cylinders

6

RATED HORSE POWER

470 kW (639 PS) @ 2,100rpm (ISO14396, Gross) (T3)
469 kW (629 PS) @ 2,000rpm (ISO14396, Gross) (T4F,S5)

Max torque

282.4 kgf.m @ 1,400 rpm (T3)
301.1 kgf.m @ 1,300 rpm (T4F,S5)

Piston displacement

18.1 l

Bore & stroke

∅ 145 mm x 183 mm

STARTING MOTOR

24 V x 9.0 kW

batteries

24 V (12 V X 2 / 200 AH)

Air cleaner

Double element with precleaner

HYDRAULIC SYSTEM

The heart of the system is the EPOSTM (Electronic Power Optimizing System). It allows the efficiency of the system to be optimized for all working conditions and minimizes fuel consumption. The new EPOSTM is connected to the engine electronic control via a data transfer link to harmonize the operation of the engine and hydraulics.

- The hydraulic system enables independent or combined operations.
- Two travel speeds offer either increased torque or high speed tracking.
- Cross-sensing pump system for fuel savings.
- Auto deceleration system.
- Two operating modes, two power modes.
- Button control of flow in auxiliary equipment circuits.
- Computer-aided pump power control.

Main pumps

Tandem, Axial piston
max flow : 3 X 523 l/min @ 100 bar, 1,800 rpm
Displacement : 280 X 3 cc/rev

Pilot pump

Gear pump - max flow : 60 l/min
Pilot pump : 32 cc/rev

Main relief Pressure

Main Relief Valve Pressure : 360 bar (367 kgf/cm²)
Travel Crossover Relief Valve Pressure : 368 bar (375 kgf/cm²)
Swing Crossover Relief Valve Pressure : 294 bar (300 kgf/cm²)

WEIGHT

Shoe Width	Ground Pressure	Machine Weight
STD. 650DG mm	1.37 kgf/cm ²	97.0 ton
OPT. 750DG mm	1.19 kgf/cm ²	97.6 ton
OPT. 750DG mm	1.20 kgf/cm ²	98.3 ton
OPT. 900DG mm	1.01 kgf/cm ²	99.5 ton

BUCKET

Bucket Type	Capacity (m ³)	Width (mm)	
	SAE/PCSA	W / O Cutter	With Cutter
S Class	5.4	1,940	1,940
	6.8	2,320	2,320

Based on ISO 10567 and SAE J296, arm length without quick change clamp

HYDRAULIC CYLINDERS

The piston rods and cylinder bodies are made of high-strength steel. A shock absorbing mechanism is fitted in all cylinders to ensure shock-free operation and extend piston life.

Cylinders	Quantity	Bore x Rod diameter x stroke
Boom	2	215 X 150 X 1,905 mm
Arm	1	240 X 170 X 2,020 mm
Bucket	1	210 X 145 X 1,530 mm

UNDERCARRIAGE

Chassis are of very robust construction, all welded structures are designed to limit stresses. High-quality material used for durability. Lateral chassis welded and rigidly attached to the undercarriage. Track rollers lubricated for life, idlers and sprockets fitted with floating seals. Tracks shoes made of induction-hardened alloy with triple grousers. Heat-treated connecting pins. Hydraulic track adjuster with shock-absorbing tension mechanism.

Upper rollers - 3
 Lower rollers - 9
 Track shoes - 51
 Overall track length - 6,370mm

SWING MECHANISM

High-torque, axial piston motor with planetary reduction gear bathed in oil. Swing circle is singlerow, shear type ball bearing with induction-hardened internal gear. Internal gear and pinion gear immersed in lubricant.

Max. Swing speed - 6.3 rpm
 Max. Swing speed - 6.1 rpm
 Max. Swing Torque - 39,330 kgf.m (386 kN.m)
 Max. Swing Torque - 31,850 kgf.m (312 kN.m)

DRIVE

Each track is driven by an independent, high-torque, axial piston motor through planetary reduction gear. Two levers or foot pedal control provide smooth travel or counter-rotation upon demand.

Travel speed (High / low) - 4.5 / 2.6 km/h
 Maximum traction force - 60.6 / 36.9 ton
 Grade ability - 70%

REFILL CAPACITIES

Fuel tank - 1100 l
 Cooling system - 99.8 l
 Engine oil - 65 l
 Swing drive - 2 X 8 l
 Final drive - 2 X 25 l
 Hydraulic tank - 880 l

BUCKET DIGGING FORCES

Bucket Type	Capacity (m ³)	Width (mm)		Digging force (ton)
	SAE/PCSA	W / O Cutter	With Cutter	
S Class	5.4	1,940	1,940	STD/OPT [SAE] 40 / 44.8 [ISO] 42.96 / 48.2
	6.8	2,320	2,320	

ARM DIGGING FORCES

Arm	Length	Weight	Digging force (ton)
Standard	3,750 mm	3,563 kg	[SAE] 36.22, [ISO] 36.73
Short	2,900 mm	3,283 kg	[SAE] 40.3, [ISO] 40.8

DIMENSION

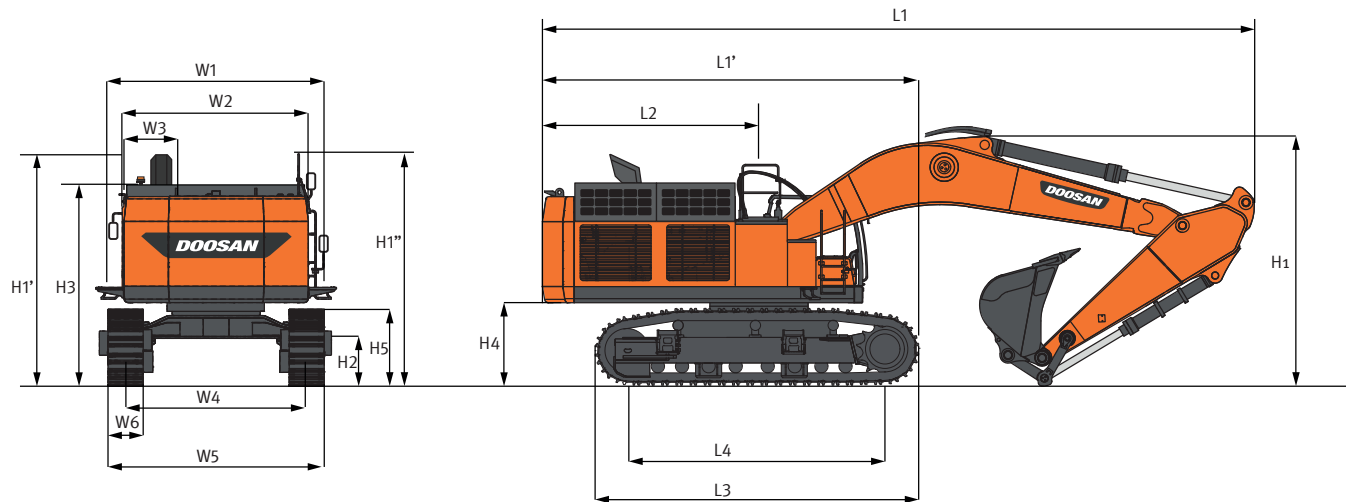

DIMENSIONS

BOOM TYPE(ONE PIECE)			mm	7,250	8,400
ARM TYPE			mm	2,900	3,750
BUCKET TYPE			m ³	6.8	5.4
Under Carriage(Grouser)				650DG	650DG
L1	Overall Length		mm	13,800	14,550
H1	Overall Height	Boom	mm	5,090	5,450
		Hose	mm	5,150	5,550
		Cabin	mm	3,615	
		Hand/Guard Rail	mm	4,175	
W1	Overall Width (Shipping)	mm	3,440		
	Rear Swing Radius	mm	4,620		
H2	Ground Clearance	mm	*860		
L2	Rear End Distance	mm	4,565		
W2	House Width	mm	***3,410/4,450		
W3	Cabin Width	mm	1,010		
H3	Height Over Cover [Bonet]	mm	3,785		
H4	Counterweight Clearance	mm	*1,560/1,615		
H5	Track Height	mm	*1,350/1,405		
L3	Track Length	mm	6,341		
L4	Tumbler Distance	mm	5,100		
W5	Undercarriage Width [without step]	mm	***3,440/4,200		
	Undercarriage Width [with step]	mm	***3,732/4,492		
W6	Shoe Width	mm	650		
	Grouser Height	mm	52		

* : Without Grouser

WORKING RANGE

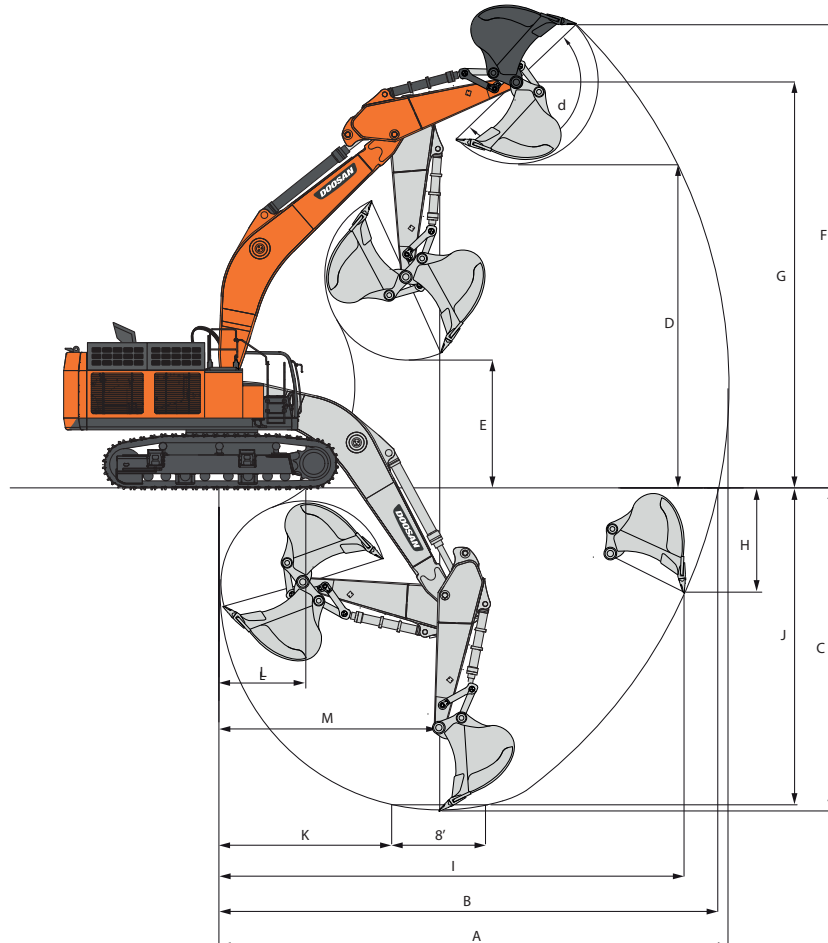

WORKING RANGE

BOOM TYPE(ONE PIECE)		mm	7,250	8,400
ARM TYPE		mm	2,900	3,750
BUCKET TYPE		m ³	6.8	5.4
A	MAX. DIGGING REACH	mm	12,430	14,275
B	MAX. DIGGING REACH (GROUND)	mm	12,110	14,000
C	MAX. DIGGING DEPTH	mm	7,260	8,795
D	MAX. LOADING HEIGHT	mm	8,100	9,440
E	MIN. LOADING HEIGHT	mm	3,910	4,210
F	MAX. DIGGING HEIGHT	mm	12,425	13,840
G	MAX. BUCKET PIN HEIGHT	mm	10,515	11,862
H	MAX. VERTICAL WALL DEPTH	mm	2,965	4,470
I	MAX. RADIUS VERTICAL	mm	10,995	12,265
J	MAX. DEPTH TO 8' LINE	mm	7,110	8,665
K	MIN. RADIUS 8' LINE	mm	4,410	5,290
L	MIN. DIGGING REACH	mm	1,970	3,365
M	MIN. SWING RADIUS	mm	5,345	6,295
d	BUCKET ANGLE	mm	145.3	143.8

LIFTING CAPACITY

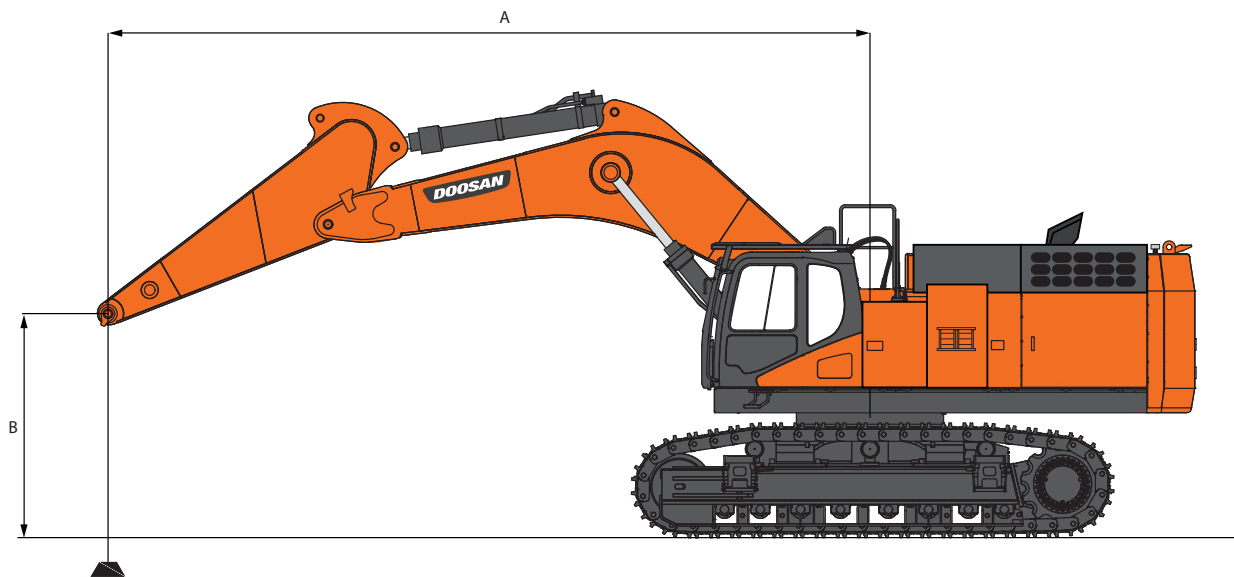

STANDARD

Metric

Boom: 7,250 mm (23'9") Arm: 2,900 mm (9'6") Shoe: 650 mm (2'1") Counter Weight: 12,760 kg (28,126lb)

A(m) \ B(m)	4.5		6		7.5		9		Max		Reach (m)
10.5									19.98 *	19.98 *	Max. at(m) 6.40
9					21.16 *	21.16 *			17.95 *	17.95 *	Max. at(m) 7.90
7.5					21.36 *	21.36 *			17.12 *	17.12 *	Max. at(m) 8.91
6 m			26.69 *	26.69 *	22.77 *	22.77 *	20.63 *	19.84	16.94 *	16.94 *	Max. at(m) 9.57
4.5 m			30.62 *	30.62 *	24.73 *	24.73 *	21.48 *	19.26	17.25 *	16.35	Max. at(m) 9.96
3 m			34.06 *	33.81	26.63 *	24.38	22.42 *	18.64	18.06 *	15.64	Max. at(m) 10.10
1.5 m			35.83 *	32.51	27.90 *	23.51	23.05 *	18.13	19.47 *	15.55	Max. at(m) 10.02
0 m			35.76 *	31.96	28.14 *	23.02	22.94 *	17.83	20.80 *	16.12	Max. at(m) 9.70
-1.5 m	43.15 *	43.15 *	34.02 *	31.92	27.04 *	22.91	21.42 *	17.87	20.89 *	17.57	Max. at(m) 9.13
-3 m	37.87 *	37.87 *	30.36 *	30.36 *	23.91 *	23.25			20.57 *	20.57	Max. at(m) 8.23
-4.5 m	29.38 *	29.38 *	23.41 *	23.41 *					19.02 *	19.02 *	Max. at(m) 6.89

Feet

A(ft) \ B(ft)	15		20		25		30		Max		Reach (ft)
35 FT									44.04 *	44.04 *	Max. at(ft) 20.99
30 FT					46.64 *	46.64 *			39.57 *	39.57 *	Max. at(ft) 25.93
25 FT					47.08 *	47.08 *			37.73 *	37.73 *	Max. at(ft) 29.23
20 FT			58.84 *	58.84 *	50.20 *	50.20 *	45.49 *	43.74	37.34 *	37.34 *	Max. at(ft) 31.39
15 FT			67.52 *	67.52 *	54.52 *	54.52 *	47.36 *	42.46	38.04 *	36.05	Max. at(ft) 32.67
10 FT			75.09 *	74.54	58.71 *	53.75	49.44 *	41.09	39.82 *	34.47	Max. at(ft) 33.15
5 FT			78.99 *	71.68	61.50 *	51.83	50.81 *	39.96	42.92 *	34.27	Max. at(ft) 32.88
0 FT			78.84 *	70.45	62.03 *	50.74	50.58 *	39.31	45.86 *	35.53	Max. at(ft) 31.84
-5 FT	95.13 *	95.13 *	75.00 *	70.37	59.61 *	50.51	47.22 *	39.41	46.06 *	38.74	Max. at(ft) 29.94
-10 FT	83.49 *	83.49 *	66.93 *	66.93 *	52.71 *	51.25			45.35 *	45.34	Max. at(ft) 27.00
-15 FT	64.78 *	64.78 *	51.60 *	51.60 *					41.92 *	41.92 *	Max. at(ft) 22.61











1. Load point is the end of the arm.
2. Capacities marked with an asterisk (*) are limited by hydraulic capacities.
3. Lift capacities shown do not exceed 75 % of minimum tipping loads or 87 % of hydraulic capacities.
4. The least stable position is over the side.
5. Lift capacities apply only to the machine as originally manufactured and normally equipped by the manufacturer.
6. The total mass of machine is 91,025 kg included in this mass boom 7.25 m, arm 2.9 m, 12,758 kg counterweight, 6.8 Kg bucket, all operating fluids and a 75 kg operator.
7. Lift capacities are in compliance with ISO 10567.

: Rating Over Front
 : Rating Over Side or 360 Degree











OPTION 1

Metric

Boom: 7,250 mm (23'9") Arm: 2,900 mm (9'6") Shoe: 750 mm (2'4") Counter Weight: 12,760 kg (28,126lb)

A(m) B(m)	4.5		6		7.5		9		Max		Reach (m)
											
10.5									19.98 *	19.98 *	Max. at(m) 6.40
9					21.16 *	21.16 *			17.95 *	17.95 *	Max. at(m) 7.90
7.5					21.36 *	21.36 *			17.12 *	17.12 *	Max. at(m) 8.91
6			26.69 *	26.69 *	22.77 *	22.77 *	20.63 *	19.96	16.94 *	16.94 *	Max. at(m) 9.57
4.5			30.62 *	30.62 *	24.73 *	24.73 *	21.48 *	19.39	17.25 *	16.46	Max. at(m) 9.96
3			34.06 *	34.03	26.63 *	24.54	22.42 *	18.76	18.06 *	15.74	Max. at(m) 10.10
1.5			35.83 *	32.73	27.90 *	23.67	23.05 *	18.25	19.47 *	15.65	Max. at(m) 10.02
0			35.76 *	32.17	28.14 *	23.17	22.94 *	17.96	20.80 *	16.23	Max. at(m) 9.70
-1.5	43.15 *	43.15 *	34.02 *	32.13	27.04 *	23.07	21.42 *	18	20.89 *	17.69	Max. at(m) 9.13
-3	37.87 *	37.87 *	30.36 *	30.36 *	23.91 *	23.4			20.57 *	20.57 *	Max. at(m) 8.23
-4.5	29.38 *	29.38 *	23.41 *	23.41 *					19.02 *	19.02 *	Max. at(m) 6.89

Feet

A(ft) B(ft)	15		20		25		30		Max		Reach (ft)
											
35									44.04 *	44.04 *	Max. at(ft) 20.99
30					46.64 *	46.64 *			39.57 *	39.57 *	Max. at(ft) 25.93
25					47.08 *	47.08 *			37.73 *	37.73 *	Max. at(ft) 29.23
20			58.84 *	58.84 *	50.20 *	50.20 *	45.49 *	44.01	37.34 *	37.34 *	Max. at(ft) 31.39
15			67.52 *	67.52 *	54.52 *	54.52 *	47.36 *	42.74	38.04 *	36.29	Max. at(ft) 32.67
10			75.09 *	75.01	58.71 *	54.1	49.44 *	41.36	39.82 *	34.71	Max. at(ft) 33.15
5			78.99 *	72.15	61.50 *	52.18	50.81 *	40.23	42.92 *	34.51	Max. at(ft) 32.88
0			78.84 *	70.92	62.03 *	51.09	50.58 *	39.59	45.86 *	35.78	Max. at(ft) 31.84
-5	95.13 *	95.13 *	75.00 *	70.84	59.61 *	50.85	47.22 *	39.68	46.06 *	39.01	Max. at(ft) 29.94
-10	83.49 *	83.49 *	66.93 *	66.93 *	52.71 *	51.6			45.35 *	45.35 *	Max. at(ft) 27.00
-15	64.78 *	64.78 *	51.60 *	51.60 *					41.92 *	41.92 *	Max. at(ft) 22.61

- Load point is the end of the arm.
- Capacities marked with an asterisk (*) are limited by hydraulic capacities.
- Lift capacities shown do not exceed 75 % of minimum tipping loads or 87 % of hydraulic capacities.
- The least stable position is over the side.
- Lift capacities apply only to the machine as originally manufactured and normally equipped by the manufacturer.
- The total mass of machine is 91,637 kg included in this mass boom 7.25 m, arm 2.9 m, 12,758 kg counterweight, 6.8 Kg bucket, all operating fluids and a 75 kg operator.
- Lift capacities are in compliance with ISO 10567.

 : Rating Over Front













 : Rating Over Side or 360 Degree

LIFTING CAPACITY













OPTION 2

Metric



Boom: 8,400 mm (27'6") Arm: 3,700 mm (12'1") Shoe: 750 mm (2'4") Counter Weight: 12,760 kg (28,126lb)

A(m) B(m)	4.5		6		7.5		9		10.5		Max		Reach (m)
													
10.5							15.25 *	15.25 *			14.63 *	14.63 *	Max. at(m) 9.06
9							17.95 *	17.95 *			13.90 *	13.90 *	Max. at(m) 10.17
7.5					20.71 *	20.71 *	18.47 *	18.47 *	17.01 *	15.53	13.63 *	13.63 *	Max. at(m) 10.96
6					22.52 *	22.52 *	19.41 *	19.41 *	17.35 *	15.18	13.67 *	12.87	Max. at(m) 11.50
4.5					24.49 *	24.49 *	20.48 *	18.75	17.86 *	14.69	14.00 *	12	Max. at(m) 11.83
3					26.09 *	23.34	21.41 *	17.91	18.30 *	14.19	14.64 *	11.53	Max. at(m) 11.95
1.5					26.88 *	22.31	21.92 *	17.22	18.47 *	13.76	15.63 *	11.42	Max. at(m) 11.88
0					26.68 *	21.71	21.80 *	16.76	18.16 *	13.46	15.67 *	11.67	Max. at(m) 11.62
-1.5			31.29 *	30.12	25.46 *	21.48	20.88 *	16.55	17.09 *	13.36	15.37 *	12.36	Max. at(m) 11.14
-3	33.04 *	33.04 *	28.04 *	28.04 *	23.16 *	21.56	18.91 *	16.61			14.81 *	13.68	Max. at(m) 10.43
-4.5	27.13 *	27.13 *	23.42 *	23.42 *	19.41 *	19.41 *	15.18 *	15.18 *			13.70 *	13.70 *	Max. at(m) 9.41
-6			16.64 *	16.64 *	13.05 *	13.05 *					11.34 *	11.34 *	Max. at(m) 7.98

Feet

A(ft) B(ft)	15		20		25		30		35		Max		Reach (ft)
													
35							33.63 *	33.63 *			32.26 *	32.26 *	Max. at(ft) 29.72
30							39.57 *	39.57 *			30.65 *	30.65 *	Max. at(ft) 33.37
25					45.66 *	45.66 *	40.71 *	40.71 *	37.49 *	34.25	30.04 *	30.04 *	Max. at(ft) 35.97
20					49.64 *	49.64 *	42.78 *	42.78 *	38.25 *	33.47	30.14 *	28.38	Max. at(ft) 37.74
15					53.99 *	53.99 *	45.16 *	41.33	39.37 *	32.39	30.87 *	26.45	Max. at(ft) 38.80
10					57.52 *	51.45	47.20 *	39.47	40.35 *	31.28	32.26 *	25.43	Max. at(ft) 39.21
5					59.26 *	49.19	48.32 *	37.96	40.72 *	30.33	34.47 *	25.18	Max. at(ft) 38.98
0					58.82 *	47.86	48.06 *	36.94	40.04 *	29.68	34.55 *	25.74	Max. at(ft) 38.11
-5			68.99 *	66.39	56.14 *	47.35	46.04 *	36.49	37.68 *	29.46	33.88 *	27.26	Max. at(ft) 36.55
-10	72.85 *	72.85 *	61.82 *	61.82 *	51.05 *	47.54	41.69 *	36.62			32.66 *	30.16	Max. at(ft) 34.20
-15	59.81 *	59.81 *	51.64 *	51.64 *	42.80 *	42.80 *	33.46 *	33.46 *			30.21 *	30.21 *	Max. at(ft) 30.86
-20			36.68 *	36.68 *	28.77 *	28.77 *					25.01 *	25.01 *	Max. at(ft) 26.19













1. Load point is the end of the arm.
2. Capacities marked with an asterisk (*) are limited by hydraulic capacities.
3. Lift capacities shown do not exceed 75 % of minimum tipping loads or 87 % of hydraulic capacities.
4. The least stable position is over the side.
5. Lift capacities apply only to the machine as originally manufactured and normally equipped by the manufacturer.
6. The total mass of machine is 92,521 kg included in this mass boom 8.4 m, arm 3.7 m, 12758 kg counterweight, 5.4 Kg bucket, all operating fluids and a 75 kg operator.
7. Lift capacities are in compliance with ISO 10567.

 : Rating Over Front
 : Rating Over Side or 360 Degree













OPTION 3

Metric



Boom: 8,400 mm (27'6") Arm: 3,700 mm (12'1") Shoe: 900 mm (2'9") Counter Weight: 12,760 kg (28,126lb)

A(m) B(m)	4.5		6		7.5		9		10.5		Max		Reach (m)
													
10.5							15.25 *	15.25 *			14.63 *	14.63 *	Max. at(m) 9.06
9							17.95 *	17.95 *			13.90 *	13.90 *	Max. at(m) 10.17
7.5					20.71 *	20.71 *	18.47 *	18.47 *	17.01 *	15.73	13.63 *	13.63 *	Max. at(m) 10.96
6					22.52 *	22.52 *	19.41 *	19.41 *	17.35 *	15.38	13.67 *	13.05	Max. at(m) 11.50
4.5					24.49 *	24.49 *	20.48 *	18.99	17.86 *	14.89	14.00 *	12.17	Max. at(m) 11.83
3					26.09 *	23.64	21.41 *	18.15	18.30 *	14.39	14.64 *	11.7	Max. at(m) 11.95
1.5					26.88 *	22.62	21.92 *	17.46	18.47 *	13.96	15.63 *	11.6	Max. at(m) 11.88
0					26.68 *	22.01	21.80 *	17	18.16 *	13.66	15.67 *	11.85	Max. at(m) 11.62
-1.5			31.29 *	30.53	25.46 *	21.78	20.88 *	16.79	17.09 *	13.56	15.37 *	12.55	Max. at(m) 11.14
-3	33.04 *	33.04 *	28.04 *	28.04 *	23.16 *	21.87	18.91 *	16.85			14.81 *	13.88	Max. at(m) 10.43
-4.5	27.13 *	27.13 *	23.42 *	23.42 *	19.41 *	19.41 *	15.18 *	15.18 *			13.70 *	13.70 *	Max. at(m) 9.41
-6			16.64 *	16.64 *	13.05 *	13.05 *					11.34 *	11.34 *	Max. at(m) 7.98

Feet

A(ft) B(ft)	15		20		25		30		35		Max		Reach (ft)
													
35							33.63 *	33.63 *			32.26 *	32.26 *	Max. at(ft) 29.72
30							39.57 *	39.57 *			30.65 *	30.65 *	Max. at(ft) 33.37
25					45.66 *	45.66 *	40.71 *	40.71 *	37.49 *	34.69	30.04 *	30.04 *	Max. at(ft) 35.97
20					49.64 *	49.64 *	42.78 *	42.78 *	38.25 *	33.91	30.14 *	28.77	Max. at(ft) 37.74
15					53.99 *	53.99 *	45.16 *	41.86	39.37 *	32.83	30.87 *	26.84	Max. at(ft) 38.80
10					57.52 *	52.12	47.20 *	40.01	40.35 *	31.72	32.26 *	25.8	Max. at(ft) 39.21
5					59.26 *	49.86	48.32 *	38.49	40.72 *	30.77	34.47 *	25.56	Max. at(ft) 38.98
0					58.82 *	48.53	48.06 *	37.48	40.04 *	30.12	34.55 *	26.13	Max. at(ft) 38.11
-5			68.99 *	67.31	56.14 *	48.02	46.04 *	37.02	37.68 *	29.9	33.88 *	27.66	Max. at(ft) 36.55
-10	72.85 *	72.85 *	61.82 *	61.82 *	51.05 *	48.21	41.69 *	37.16			32.66 *	30.6	Max. at(ft) 34.20
-15	59.81 *	59.81 *	51.64 *	51.64 *	42.80 *	42.80 *	33.46 *	33.46 *			30.21 *	30.21 *	Max. at(ft) 30.86
-20			36.68 *	36.68 *	28.77 *	28.77 *					25.01 *	25.01 *	Max. at(ft) 26.19

1. Load point is the end of the arm.
2. Capacities marked with an asterisk (*) are limited by hydraulic capacities.
3. Lift capacities shown do not exceed 75 % of minimum tipping loads or 87 % of hydraulic capacities.
4. The least stable position is over the side.
5. Lift capacities apply only to the machine as originally manufactured and normally equipped by the manufacturer.
6. The total mass of machine is 93,714 kg included in this mass boom 8.4 m, arm 3.7 m, 12758 kg counterweight, 5.4 Kg bucket, all operating fluids and a 75 kg operator.
7. Lift capacities are in compliance with ISO 10567.

 : Rating Over Front
 : Rating Over Side or 360 Degree

STANDARD & OPTION

STANDARD EQUIPMENT

Hydraulic system

- Boom and arm flow regeneration
- Boom and arm holding valves
- Swing anti-rebound valves
- Spare ports (Control valve)

Cabin & Interior

- Viscous cab mounts
- All weather sound suppressed type cab
- Air conditioner & Heater
- Adjustable suspension seat with head rest and adjustable arm rest
- Pull-up type front window and removable lower front window
- Room light
- Intermittent windshield wiper
- Cigarette lighter and ashtray
- Cup holder
- Hot & Cool box
- LCD color monitor panel
- E/G RPM control dial
- AM/FM radio + MP3 (USB)
- Remote radio ON/OFF switch
- 12V spare powers socket
- Serial communication port for laptop PC interface
- Joystick lever with 3 switches
- Sun visor
- Sun roof

Safety

- Large handrails and step
- Convex metal anti-slip plates
- Seat belt
- Hydraulic safety lock lever
- Safety glass
- Hammer for emergency escape
- Right and left rearview mirrors
- Battery protector cover

Others

- Double element air cleaner with two stage filtration
- Water separator
- Fuel filter
- Dust screen for radiator/oil cooler
- Engine overheat prevention system
- Engine restart prevention system
- Self-diagnostic system
- Alternator (24 V, 115 A)
- Electric horn
- LED working lights (boom mounted 2, frame mounted 2, storage box mounted 1)
- Hydraulic track adjuster
- Track guards
- Greased and sealed track link
- Hydraulic oil tank air breather filter

OPTIONAL EQUIPMENT

Some of optional equipments may be standard in some markets. Some of this optional equipment is not available in some markets. You must check with the local DOOSAN dealer to know about the availability or to release the adaptation following the needs of the applications

Arm <ul style="list-style-type: none"> • 2.9 m Arm • 3.75 m Arm 	Lever Pattern Change <ul style="list-style-type: none"> • Lever Pattern Change 	Additional Work Lamp <ul style="list-style-type: none"> • 2 Additional Working Lamp(LED) • 6 Additional Working Lamp(LED)
Boom <ul style="list-style-type: none"> • 8.4 m Boom • 7.25 m Boom 	One & Two Way Front Piping <ul style="list-style-type: none"> • One & Two Way Front Piping 	Lower Wiper <ul style="list-style-type: none"> • Lower Wiper
Bucket (SAE/PSCA) <ul style="list-style-type: none"> • 5.4 m³ S Class Bucket • 6.8 m³ S Class Bucket • Only Dummy Link No Bucket 	Rotating Piping(PERO) <ul style="list-style-type: none"> • Rotating Piping(PERO) 	Overload Warning Device <ul style="list-style-type: none"> • Overload Warning Device
Boom Cylinder Guard <ul style="list-style-type: none"> • Boom Cylinder Guard 	One & Two Way Piping <ul style="list-style-type: none"> • Mono Two Way with Pedal • Mono Two Way without Pedal • Mono One Way with Electric Ped • Mono One Way 	Rotating Beacon <ul style="list-style-type: none"> • Rotating Beacon
Bucket Cylinder Guard <ul style="list-style-type: none"> • Bucket Cylinder Guard 	Quick Coupler Piping <ul style="list-style-type: none"> • Quick Coupler Piping 	Cabin Roof Cover <ul style="list-style-type: none"> • Plastic Roof Cover • Steel Roof Cover
Track Guard <ul style="list-style-type: none"> • 650 mm Double Grouser Shoe • 750 mm Double Grouser Shoe • 900 mm Double Grouser Shoe 	Straight Travel <ul style="list-style-type: none"> • Straight Travel 	Water Separator With Heater <ul style="list-style-type: none"> • Water Separator with Heater • Water Separator without Heater
Breaker Filter <ul style="list-style-type: none"> • Breaker Filter 	Two Pumps & Piping <ul style="list-style-type: none"> • Two Pumps 	Telematics <ul style="list-style-type: none"> • 1.5 Global Dual (SAT+Cell) • 2.0 CHINA (Cell only) • 2.0 Global (Cell only) • 2.0 Global Dual(SAT+Cell)
Hydraulic Oil <ul style="list-style-type: none"> • Cold Weather (VG32) • Normal Weather (VG46) • Tropical Weather (VG68) 	Audio Equipment <ul style="list-style-type: none"> • Radio+MP3(Stereo) 	Air Compressor <ul style="list-style-type: none"> • Air Compressor
FOGS Guard <ul style="list-style-type: none"> • FOGS • Top Guard 	Rain Shield <ul style="list-style-type: none"> • Rain Shield 	Auto Greasing Unit <ul style="list-style-type: none"> • Auto Greasing Unit
Mirror <ul style="list-style-type: none"> • Side Mirror 	Alarm <ul style="list-style-type: none"> • Alarm for Travel and Swing 	Additional Mirror <ul style="list-style-type: none"> • Additional Mirror
	Camera <ul style="list-style-type: none"> • Around View Camera • Rear View Camera 	Fuel Filler Pump <ul style="list-style-type: none"> • Fuel Filler Pump
	Cabin Front Guard <ul style="list-style-type: none"> • Upper and Lower Guard • Lower Guard Only 	
	Under Cover <ul style="list-style-type: none"> • Standard Under Cover 	

*Above option list could be changed without notice